

microATX Motherboard Interface Specification

Version 1.1

IMPORTANT INFORMATION AND DISCLAIMERS

1. INTEL CORPORATION MAKES NO WARRANTIES WITH REGARD TO THIS SPECIFICATION (“SPECIFICATION”), AND IN PARTICULAR DOES NOT WARRANT OR REPRESENT THAT THIS SPECIFICATION OR ANY PRODUCTS MADE IN CONFORMANCE WITH IT WILL WORK IN THE INTENDED MANNER. NOR DOES INTEL ASSUME RESPONSIBILITY FOR ANY ERRORS THAT THE SPECIFICATION MAY CONTAIN OR HAVE ANY LIABILITIES OR OBLIGATIONS FOR DAMAGES INCLUDING, BUT NOT LIMITED TO, SPECIAL, INCIDENTAL, INDIRECT, PUNITIVE, OR CONSEQUENTIAL DAMAGES WHETHER ARISING FROM OR IN CONNECTION WITH THE USE OF THIS SPECIFICATION IN ANY WAY.
2. NO REPRESENTATIONS OR WARRANTIES ARE MADE THAT ANY PRODUCT BASED IN WHOLE OR IN PART ON THE ABOVE SPECIFICATION WILL BE FREE FROM DEFECTS OR SAFE FOR USE FOR ITS INTENDED PURPOSE. ANY PERSON MAKING, USING OR SELLING SUCH PRODUCT DOES SO AT HIS OR HER OWN RISK.
3. THE USER OF THIS SPECIFICATION HEREBY EXPRESSLY ACKNOWLEDGES THAT THE SPECIFICATION IS PROVIDED AS IS, AND THAT INTEL CORPORATION MAKES NO REPRESENTATIONS, EXTENDS NO WARRANTIES OF ANY KIND, EITHER EXPRESS OR IMPLIED, ORAL OR WRITTEN, INCLUDING ANY WARRANTY OF MERCHANTABILITY OR FITNESS FOR A PARTICULAR PURPOSE, OR WARRANTY OR REPRESENTATION THAT THE SPECIFICATION OR ANY PRODUCT OR TECHNOLOGY UTILIZING THE SPECIFICATION OR ANY SUBSET OF THE SPECIFICATION WILL BE FREE FROM ANY CLAIMS OF INFRINGEMENT OF ANY INTELLECTUAL PROPERTY, INCLUDING PATENTS, COPYRIGHT AND TRADE SECRETS NOR DOES INTEL ASSUME ANY OTHER RESPONSIBILITIES WHATSOEVER WITH RESPECT TO THE SPECIFICATION OR SUCH PRODUCTS.
4. A LICENSE IS HEREBY GRANTED TO COPY AND REPRODUCE THIS SPECIFICATION FOR ANY PURPOSE PROVIDED THIS “IMPORTANT INFORMATION AND DISCLAIMERS” SECTION (PARAGRAPHS 1-4) IS PROVIDED IN WHOLE. NO OTHER LICENSE, EXPRESS OR IMPLIED, BY ESTOPPEL OR OTHERWISE, TO ANY OTHER INTELLECTUAL PROPERTY RIGHTS IS GRANTED HEREIN.

Copyright © 1996, 1997, 2002 Intel Corporation. All rights reserved.

Version 1.1, June, 2002

† Other product and corporate names may be trademarks or registered trademarks of other companies, and are used only for explanation and to the owners' benefit, without intent to infringe.

†† Wake on LAN is a trademark of IBM corporation

Revision History

Changes from Version 1.0 to Version 1.1

Global—Removed references to AT, Baby AT, and Mini-ATX.

Section 1—Revised introductory paragraph, updated the specification Web site URL, and changed ATX 2.01 to ATX 2.1 in Table 1.

Section 1.1—Updated Web site URL and list of related documents.

Section 1.2—Revised Figure 1.

Section 2.3.4—Replaced Figure 4. Updated the text in the paragraph immediately preceding Figure 5: corrected the dimensions of the hatched area in Figure 5. Replaced Figure 6.

Section 2.4—Moved text in Section 2.4 under a new subheading, 2.4.1. Added subheading, 2.4.2, to specify secondary side height constraints. Revised Figure 7 to reflect an increase in the maximum component height restriction. Zones C, D, and E formerly specified three different height restrictions. This revision replaces those three zones (C, D, and E) with one maximum component height restriction zone (C) for the entire region.

Section 3—Removed discrepancies between this document and the *SFX/SFX12V Power Supply Design Guide*.

Section 3.2—Added new section titled “2x2 Connector” to describe a new +12V power connector. Renumbered subsequent sections.

Global—Replaced ATX 2.01 with ATX 2.1, where appropriate. Replaced SFX with SFX/SFX12V, where appropriate.

Contents

1.	Executive Summary	6
1.1	Other Technical Documents	6
1.2	microATX Form-factor Overview	7
1.3	Benefits to Users	8
1.4	Benefits to Manufacturers.....	8
1.5	Mounting microATX Motherboard in an ATX Chassis.....	8
2.	Layout	9
2.1	Board Dimensions	9
2.2	Mounting Hole Placement	9
2.3	Connector Placement.....	11
2.3.1	Expansion Slots	11
2.3.2	Disk I/O.....	13
2.3.3	Front Panel I/O	13
2.3.4	Back Panel I/O.....	13
2.3.5	Memory Sockets	16
2.3.6	Processor	16
2.3.7	Power Supply Connector	16
2.4	Height Constraints.....	17
2.4.1	Primary (Component) Side Height Constraints	17
2.4.2	Secondary (Bottom/Solder) Side Height Constraints	17
3.	Power Supply Connector Information.....	19
3.1	20-pin Connector.....	19
3.2	2x2 Connector	20
3.3	Signal Control Definitions	20
3.3.1	PS-ON	20
3.3.2	5VSB	20
3.3.3	Power Good Signal, PW-OK.....	20
3.4	Voltage Tolerances.....	21
3.5	Optional 6-pin Power Connector.....	21
3.5.1	FanM Signal	22
3.5.2	FanC Signal.....	22
3.5.3	3.3V Sense Line	23
3.5.4	1394V Pin.....	23
3.5.5	1394R Pin.....	23

Figures

Figure 1: Example of a microATX System	7
Figure 2: microATX and ATX Form-factor Mounting Holes	10
Figure 3: Example microATX Layout Diagram	12
Figure 4: Chassis I/O Aperture Requirements	14
Figure 5: Motherboard I/O Connector Location Recommendation	15
Figure 6: Example Rear Panel I/O Connector Layout	16
Figure 7: microATX Motherboard Maximum Component Height Restrictions	18
Figure 8: 20-pin Main Power Supply Connector Configuration (required for microATX)	19
Figure 9: 2x2 Connector Configuration	20
Figure 10: 6-pin Optional Power Supply Connector Configuration	21
Figure 11: Simple Implementation of a Fan Monitor Circuit	22

Tables

Table 1: microATX Feature Summary.....	6
Table 2: Requirements to Mount microATX Motherboard in ATX 2.1-compliant Chassis.....	8
Table 3: microATX and ATX Board Dimensions	9
Table 4: Motherboard Mounting Hole Locations	9
Table 5: Connector Locations	11
Table 6: Height Constraints	17
Table 7: Voltage Tolerances	21

1. Executive Summary

microATX is a motherboard form factor developed as a natural evolution of the ATX form factor to address market trends and PC technologies. This specification defines the interface between the motherboard and the chassis.

microATX supports:

- Current processor technologies
- The transition to newer processor technologies
- Accelerated Graphics Port (AGP) high performance graphics solutions
- Smaller motherboard size
- Smaller power supply form factor

microATX is a public specification intended for widespread use in many types of systems. The specification and related information on microATX are available through a public Web site located at:

<http://www.formfactors.org>

Table 1 summarizes the features of the microATX form factor.

Table 1: microATX Feature Summary

Feature	Benefit
9.6" x 9.6" (244 x 244 mm) motherboard, maximum size	<ul style="list-style-type: none">• Smaller size promotes a smaller system size.• Smaller size reduces overall system cost.
Standard ATX 2.1 or later I/O panel	<ul style="list-style-type: none">• I/O shield does not need to be retooled.• Motherboard could be used in an ATX 2.1-compliant chassis (with minor modifications).
Reduced I/O slots	<ul style="list-style-type: none">• Higher integration on motherboard reduces motherboard and system costs.• A smaller power supply can be used.

Small form-factor power supplies have been defined for use with several different products, including microATX board and chassis designs. The smaller size of these power supplies encourages flexibility in choosing mounting locations within the chassis.

1.1 Other Technical Documents

For information about the following areas, see the series of microATX design guidelines and suggestions on the microATX public Web site at <http://www.formfactors.org>:

- *SFX/SFX12V Power Supply Design Guide*
- *TFX12V Power Supply Design Guide*
- *microATX Electrical Design Suggestions*
- *microATX Chassis Checklist*
- *microATX System Design Suggestions*
- *microATX EMC Design Suggestions*
- *microATX Thermal Design Suggestions*
- *Performance microATX Thermal Design Suggestions*

1.2 microATX Form-factor Overview

Figure 1 shows an example of a system using a microATX motherboard.

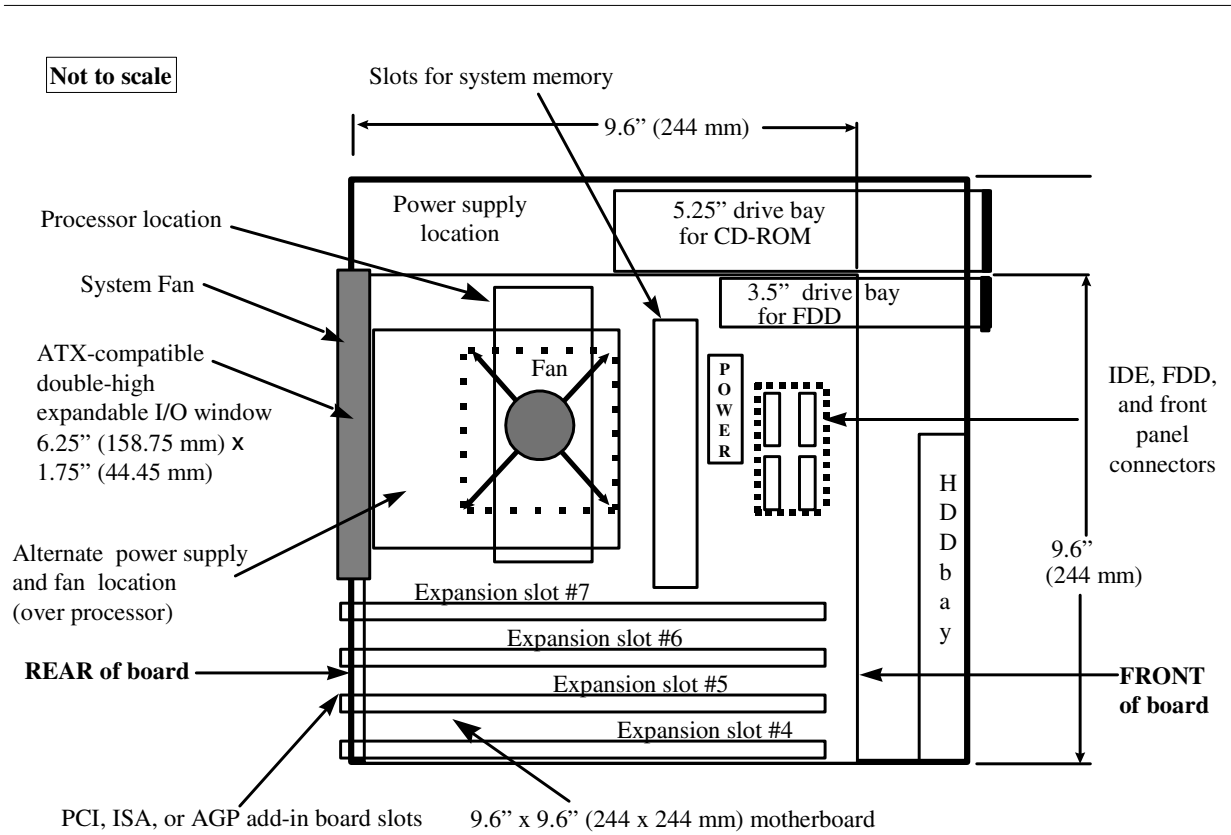

Figure 1: Example of a microATX System

(oriented for example installation in a tower, side view; front of board to the right in this figure)

Note: The example in Figure 1 shows expansion slot numbers 4 through 7. Slots 1 through 3 are present on an ATX motherboard, which is wider than a microATX board.

1.3 Benefits to Users

While offering the same benefits of the ATX form factor specification, the microATX form factor improves upon the previous specification in several key areas.

Current trends in the industry indicate that users require a lower-cost solution for their PC needs. Without sacrificing the benefits of ATX, this form factor addresses the cost requirement by reducing the size of the motherboard. The smaller motherboard is made possible by reducing the number of I/O slots. The overall effect of these size changes reduces the costs associated with the entire system design. The expected effect of these reductions is to lower the total system cost to the end user.

Another area of improvement is the reduced size of the chassis as it sits on the user's desk. This reduced size improves the aesthetic value for the end user and promotes higher satisfaction with system ownership.

1.4 Benefits to Manufacturers

Through careful designing of a microATX motherboard, an OEM can capitalize on the benefits of a reduction in total system costs. These cost savings come from a reduced-output power supply (see the separate documents *SFX/SFX12V Power Supply Design Guide* and *TFX12V Power Supply Design Guide*), reduced chassis costs, and minimal redesign of existing ATX 2.1 or later¹ compliant chassis for backward-compatibility.²

Where possible, the existing mounting locations in the microATX form factor are aligned with those that exist in ATX 2.1. This alignment reduces the possible changes to existing ATX 2.1-compliant chassis and encourages the rapid adoption of the new microATX form factor. See Section 2.2 for mounting hole locations.

microATX benefits also include those found with the current ATX form factor: more I/O space at the rear and reduced emissions from using integrated I/O connectors.

1.5 Mounting microATX Motherboard in an ATX Chassis

Table 2 lists the requirements to mount the microATX motherboard in the ATX 2.1-compliant chassis.

Table 2: Requirements to Mount microATX Motherboard in ATX 2.1-compliant Chassis

Feature	Status	Comment
Provide motherboard mounts at location R and S.	R required for full-width microATX board (9.6 inches) and S optional.	See Figures 2 and 3 and Section 2.2 for details.
Remove standoffs from any location not defined in microATX specification or use removable standoffs.	Required	To avoid damage to the traces on the microATX motherboard.
Verify that the chassis keepout in Area A is adequate to prevent mechanical interference with the chassis structure.	Required	See Table 6 and Figure 7.

¹ Throughout this document, references to ATX 2.1 refer to ATX Version 2.1 *or higher*.

² Current ATX 2.1 chassis require additional motherboard mounts for compatibility with microATX.

2. Layout

This section describes the mechanical specification of the microATX form-factor motherboard, including physical size, mounting hole placement, connector placement, and component height constraints.

2.1 Board Dimensions

Table 3 compares the microATX and ATX 2.1 board dimensions.

Table 3: microATX and ATX Board Dimensions

Dimension	microATX board	ATX board, full-sized
Maximum width allowable	9.6 inches (244 mm)	12 inches (305mm)
Maximum depth allowable	9.6 inches (244 mm)	9.6 inches (244mm)

2.2 Mounting Hole Placement

Table 4 describes motherboard mounting hole locations.

Table 4: Motherboard Mounting Hole Locations

Feature	Status	Comment
Motherboard mounting hole locations	Required	See Figure 2 for an overview and Figure 3 for exact locations.

Where possible, the microATX mounting holes line up with mounting holes used for ATX boards. Two new holes (R and S in Figure 2) have been defined and added to provide mechanical support toward the front edge of the microATX board.

- Figure 2 shows the relative outlines of the microATX and ATX boards. The letter callouts in the figure show the general location of the mounting holes for both form factors. The table in the figure indicates which holes are required for each form factor.
- Figure 3, the sample layout diagram, shows the exact location (dimensions) of the mounting holes for microATX boards.

Chassis: To achieve full microATX compliance for chassis assemblies and to provide proper support for the board in these areas, all nine microATX board mounting locations shown in Figure 2 should be implemented in the chassis.

Motherboard: The board design can incorporate any combination of the microATX mounting holes shown in Figure 2 if a given board design is smaller than the 9.6 x 9.6-inch maximum size. For a full-width microATX board, hole R is required and hole S is optional. For a board that is narrower than 9.6 inches, of the two new holes, R and S, only hole S is required.

To avoid damage to traces on microATX and ATX motherboards, chassis standoffs in any locations not specified for microATX and ATX should be removable or not be implemented at all.

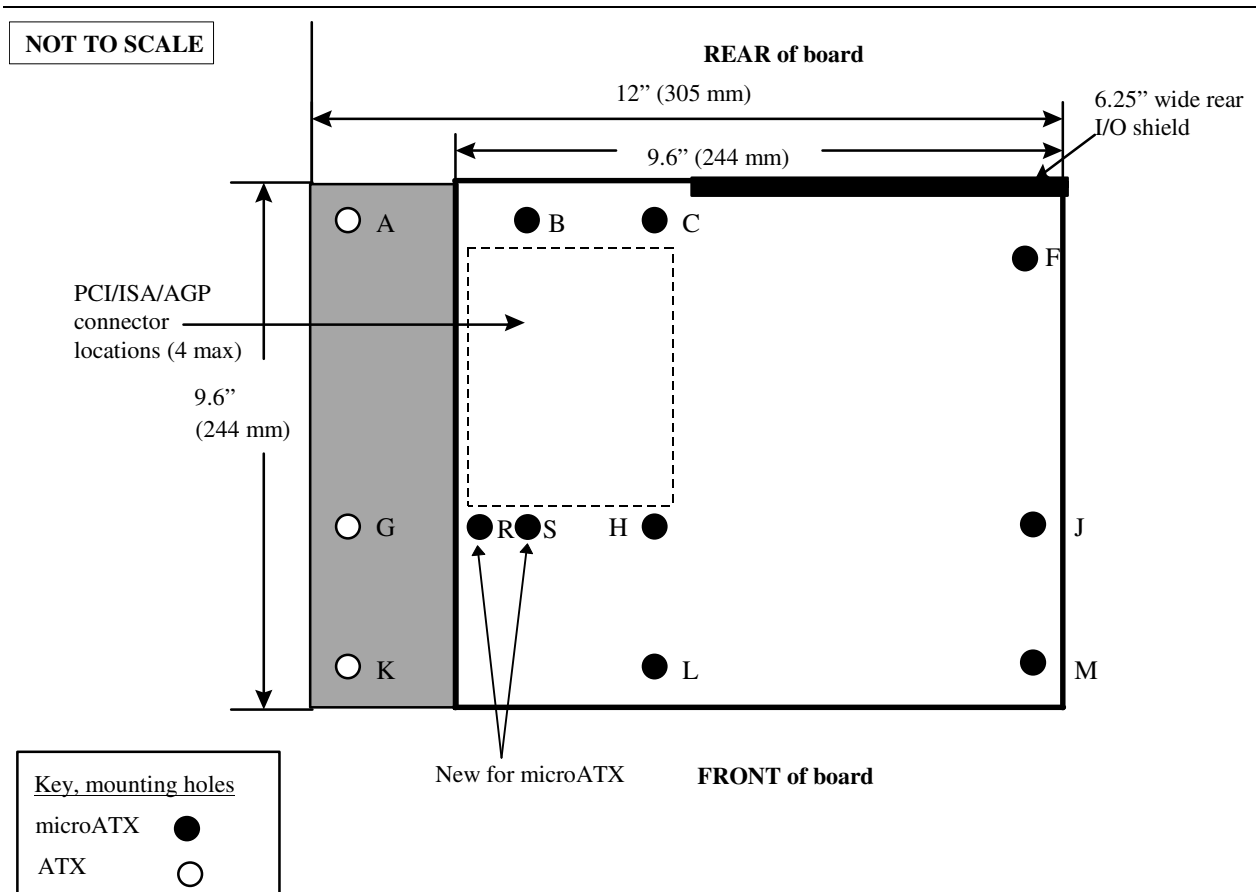

Form factor	Mounting hole locations	Notes
microATX	B, C, F, H, J, L, M, R, S	Holes R and S are added for microATX form factor. Hole B was defined in Full AT format
ATX	A, C, F, G, H, J, K, L, M	Hole F must be implemented in all ATX 2.1-compliant chassis assemblies. It was optional in the ATX 1.1 specification.

Figure 2: microATX and ATX Form-factor Mounting Holes

Notes: In Figure 2, Figure 3, and Figure 8, the board is shown oriented with the rear of the board toward the top. The shaded portion to the left above indicates the greater width of the ATX form factor. For details about mounting holes and board sizes, see the mechanical drawing in this specification.

2.3 Connector Placement

Table 5 lists connector locations. Figure 3 clearly defines the location of the PCI, ISA, and AGP connectors as well as the allowable placement area for I/O connectors on the back panel. The specification provides recommendations, but the exact location of other connectors is left to the judgment of the motherboard designer working in conjunction with the system integrator.

Table 5: Connector Locations

Feature	Status	Comment
Expansion slot connector locations	Required	See Figure 3.
Power input connector location	Recommended	Along the right-hand side of the board in Figure 3.
2x2 Processor power connector	Recommended	Next to the processor voltage regulation circuitry
Power input connector pinout	Required	See Figure 8.
Optional power connector pinout	Not required	See Figure 10 (as reference material for ATX 2. 1 or higher).
Disk I/O connector location	Recommended	Front edge of board, near drive bays.
Front panel I/O connector locations	Recommended	Front edge of board, right of expansion slots.
Back panel I/O panel size and location	Required	See Figure 4.
Back panel I/O connector zone	Recommended	See Figure 5.
Back panel I/O connector arrangement	Optional	See Figure 6 for an example.
Memory module connector location	Recommended	Between processor and expansion slots, or between processor and disk I/O connectors.
Processor location	Recommended	Right of expansion slots, in front of back panel I/O connectors.

2.3.1 Expansion Slots

The microATX form-factor supports up to **four** expansion slots. These slots can be any combination of ISA, PCI, CNR, AGP, shared ISA/PCI, or shared CNR/PCI add-in boards. Figure 3 shows a typical combination of two ISA slots and two PCI slots, one of which is a shared ISA/PCI slot. The location of pin 1 is defined for each of the connectors. If a combination other than that shown in Figure 3 is desired, motherboard designers should extrapolate the location of pin one on each of the connectors. The slot spacing must remain constant.

To allow all add-in cards to be full length, it is recommended that the height of any board component located toward the front left edge of the board (as viewed in Figure 3) be less than 0.6 inches (15.2mm) (plus clearance for the board components).

In addition to the mounting holes, for extra support during add-in board insertion the system designer can optionally choose to add mechanical support under the expansion slots. The system and board designers must decide the location and shape of any such support.

For more examples, see the *microATX System Design Suggestions*; for Web site URL, see Section 1.1.

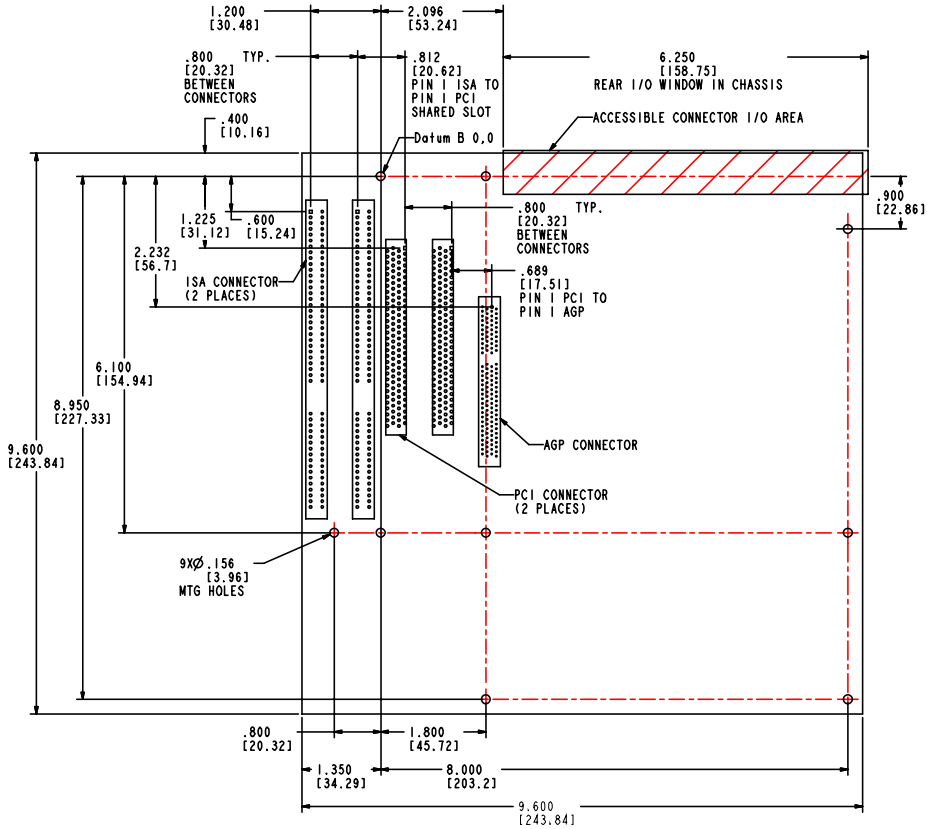

Figure 3: Example microATX Layout Diagram

Notes: Datum B 0,0 = mounting location hole B.
 In this figure, the board is shown oriented with the rear of the board toward the top.
 See *microATX Motherboard Design Suggestions* for different combinations of expansion slots.

2.3.2 Disk I/O

The exact locations of the floppy, IDE, and/or SCSI I/O connectors are not specified. It is recommended that they be placed along the front edge of the board (oriented as in Figure 3) to the right of the expansion slots. When placing connectors, the designer should keep in mind that proper clearance must be provided for the chassis peripheral bays.

2.3.3 Front Panel I/O

The exact location of the front panel I/O connector is not specified. It is recommended that the connector be placed along the front edge of the board (oriented as in Figure 3) to the right of the expansion slots. When placing the connector, the designer should keep in mind that proper clearance must be provided for the chassis peripheral bays. Locating the front panel I/O connector along the left edge of the board is not recommended because of limited clearance with a full length add-in card.

2.3.4 Back Panel I/O

With the PC platform evolving so fast, it makes sense to retain the greatest level of flexibility possible for the future for external I/O. The multimedia explosion has demonstrated how user needs for enhanced I/O can change quickly. Toward the rear of the chassis, the microATX and ATX Specifications define a stacked I/O area that is 6.25 inches (158.75mm) wide by 1.75 inches (44.45mm) tall. This area allows the use of stacked connectors on the motherboard to maximize the amount of I/O space available.

As shown in Figure 4, the bottom of the back panel opening is located 0.150 inches (3.81mm) below the top of a typical 0.062 inch (1.57 mm) thick motherboard. A 0.1 inch (2.54 mm) required keepout zone is defined around the perimeter of the cutout area, on both the inside and outside surfaces of the chassis back panel. This keepout zone provides a reserved space that can be used to clip a chassis-independent I/O shield to the chassis back panel. No slots, tabs, notches, or other topographical features should be placed within the keepout zone. If a feature violates the keepout zone, the chassis loses the opportunity to support an I/O shield that can be designed to fit all ATX chassis that meet the specifications listed below and detailed in Figure 4 and Figure 5. For best EMI attenuation performance, paint should not be applied within the keepout area, because paint can prevent proper grounding of the I/O shield. Also, motherboard connector placement must be limited as shown in Figure 5 to allow enough clearance between the connectors and chassis opening for the I/O shield structure.

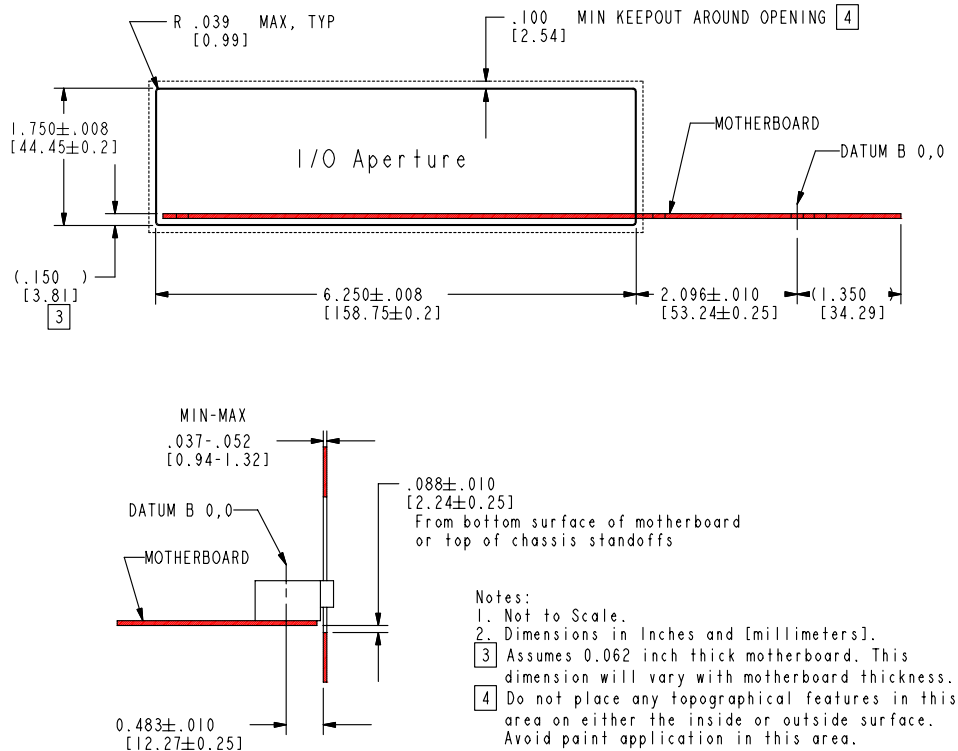

Figure 4: Chassis I/O Aperture Requirements

Notes:

- Datum B 0,0 = mounting location hole B.
- Nominal cutout size = 6.25 inches (158.75mm) by 1.75 inches (44.45mm).
- Distance from top of a typical 0.062 inches (1.57 mm) motherboard to bottom of I/O cutout hole = 0.150 inches (3.81mm).
- Allowable thickness of a chassis back panel that the I/O shield can clip into is in the range 0.037 inches (0.94mm) to 0.052 inches (1.32mm).
- The corners of the I/O aperture can be rounded to a maximum radius of .039 inches (0.99mm). This allowable rounding of the corners helps case manufacturers extend the life of their hard tooling while still complying with the specification.
- The 0.1 inches (2.54mm) keepout zone around the I/O aperture area is required in an ATX 2.1-compliant chassis. This allows microATX- and ATX 2.1-compliant I/O shields to fit into previous versions of ATX-compliant chassis. The keepout area is needed for the shield attachment points. Avoid paint application in this area.

Figure 5 specifies the I/O connector zone. Compliance with this recommendation is necessary to ensure enough clearance between the chassis aperture and motherboard connectors for the I/O shield structure. If the shield provided with the motherboard requires less than the recommended clearance, then the dimensions of the I/O connector area can be waived (hatched area in Figure 5: 5.990 inches [152.15mm] by 1.470 inches [37.34mm]). To retain maximum flexibility, the exact positioning of connectors within the I/O connector zone is left to the discretion of the motherboard designer.

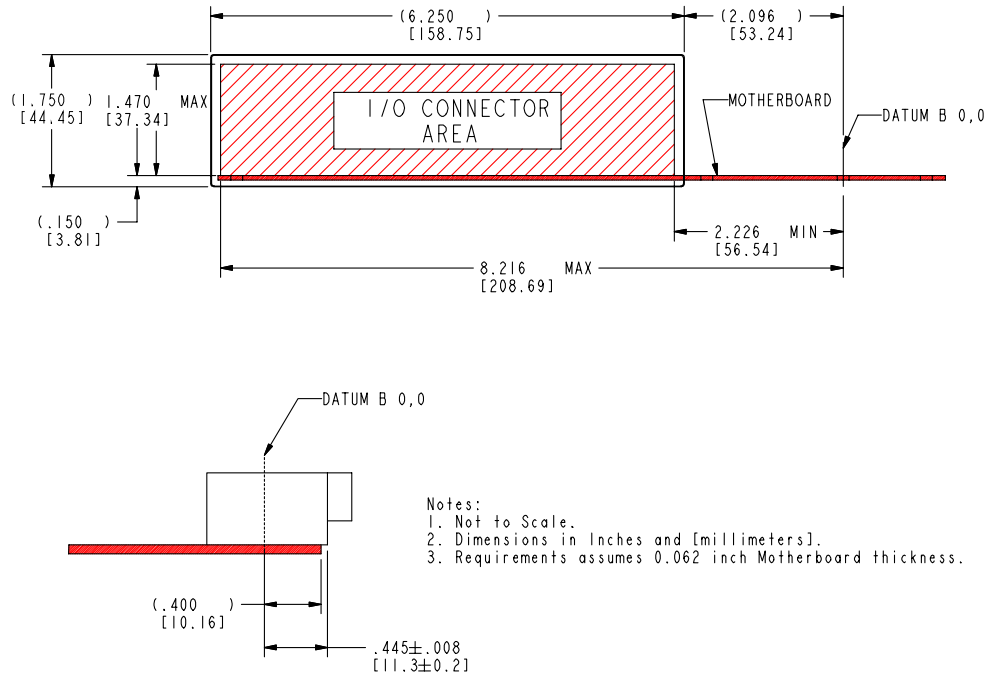

Figure 5: Motherboard I/O Connector Location Recommendation

Notes:

- Datum B 0,0 = mounting location hole B.
- The face of all I/O connectors should be placed 0.445 inches (11.30mm) from the reference datum and remain within the zone defined in Figure 5.
- The I/O aperture should be a simple cutout of the chassis back panel. Recessing the I/O aperture will prevent the case from accepting microATX- and ATX 2.1-compliant I/O shields.

Figure 6 shows an example of rear panel I/O connector layout, featuring stacked keyboard and mouse, stacked USB ports, stacked serial and parallel and VGA ports, a LAN port, and stacked audio jacks. This layout is only an example—the microATX form factor allows complete flexibility in the layout of rear panel I/O.

For more I/O panel examples, see the *microATX System Design Suggestions*; for the Web site URL, see Section 1.1.

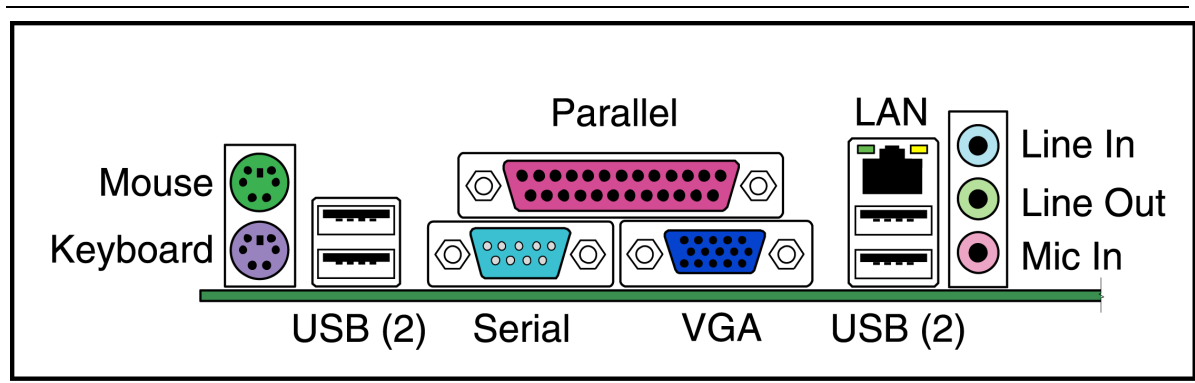

Figure 6: Example Rear Panel I/O Connector Layout

2.3.5 Memory Sockets

The exact location of the memory sockets, whether they are SIMM, DIMM, or some other type of connector, is not rigidly specified. It is the designer's responsibility to meet the keepout zone requirements. For more information, see the *microATX Motherboard Design Suggestions*; for Web site URL, see Section 1.1.

2.3.6 Processor

The exact location of the processor is not specified. It is the designer's responsibility to meet the keepout zone requirements. For more information, see the *microATX Motherboard Design Suggestions*; for Web site URL and availability date, see Section 1.1.

2.3.7 Power Supply Connector

The microATX power supply connector definition is identical to that of ATX. The exact location of the power connector is not specified. It is recommended that it be placed along the right-hand side of the board ("right" per orientation of board as shown in Figure 3), considering the location of the processor, core logic, and clearance for the peripheral bays. Locating the 2x2 processor power connector near the processor voltage regulation circuitry will help to ensure clean power and improve board layout.

The microATX system designer can use small form-factor power supplies or the standard ATX 2.1 power supply. For more information, see the *SFX/SFX12V Power Supply Design Guide* and the *TFX12V Power Supply Design Guide*; for the Web site URL, see Section 1.1.

For power connector signal definitions, see Section 3.

2.4 Height Constraints

2.4.1 Primary (Component) Side Height Constraints

One of the major advantages of the microATX form factor is its backward-compatibility with the ATX specification. The microATX motherboard can be installed in any ATX chassis with the addition of motherboard mounts. Table 6 lists the status of height constraints for specific areas. Figure 7 shows the required **maximum component height constraints** for the components on the PC board. For full compliance with microATX and to prevent interference with the chassis structure, power supply, or peripherals, the motherboard components should not exceed the height limit in each zone defined. Similarly, microATX-compliant power supplies, peripherals, and chassis features should not extend into the motherboard component area.

Table 6: Height Constraints

Feature	Status	Comment
microATX motherboard maximum component heights	Required	See Figure 7.
microATX chassis keepout in Area A	Required	3.0 inches (76.20mm) required; 3.5 inches (88.90mm) is preferred.

The **required** chassis keepout for Area A is 3.0 inches (76.20mm) to facilitate dynamic considerations of components in this area on the motherboard. The preferred (recommended) clearance is 3.5 (88.90mm) inches to facilitate cooling solutions that require ducting. The bottom right corner of the board (as oriented in Figure 7) is the most constrained because of the presence of 5.25-inch and 3.5-inch peripherals in some chassis configurations. To maintain strict compliance to the microATX specification, careful placement of peripherals, power supply, and chassis features is required.

2.4.2 Secondary (Bottom/Solder) Side Height Constraints

Required secondary (bottom) side motherboard height constraints for all areas (A-C, as shown in Figure 7) are defined as follows (measured from the bottom planar surface of the motherboard PCB):

- $\leq 0.010''$ – Mounting hole standoff areas – no components. Restriction applies within $0.400''$ square area centered on each required mounting hole location defined in Section 2.2. Nominal allowance is provided only to accommodate slight reflow solder excess.
- $\leq 0.098''$ – All board circuit components (including leads) that are electrically conductive and intolerant of direct connection to chassis ground (e.g., through-hole leads, surface mount resistors)
- $\leq 0.120''$ – Board components that are non-conductive or otherwise tolerant of direct connection to chassis ground (e.g., connector guide/stake pins)
- $\leq 0.200''$ – Devices attached to the motherboard for the sole purpose of structural retention or stiffening

A chassis and its related elements (e.g., stiffening ribs, base pan, structural supports fasteners, etc.) must allow $\geq 0.250''$ clearance to the bottom planar surface of the motherboard PCB. This does not including mounting hole standoffs, which may extend to and contact the PCB at the mounting holes within the prescribed $0.400''$ -square areas.

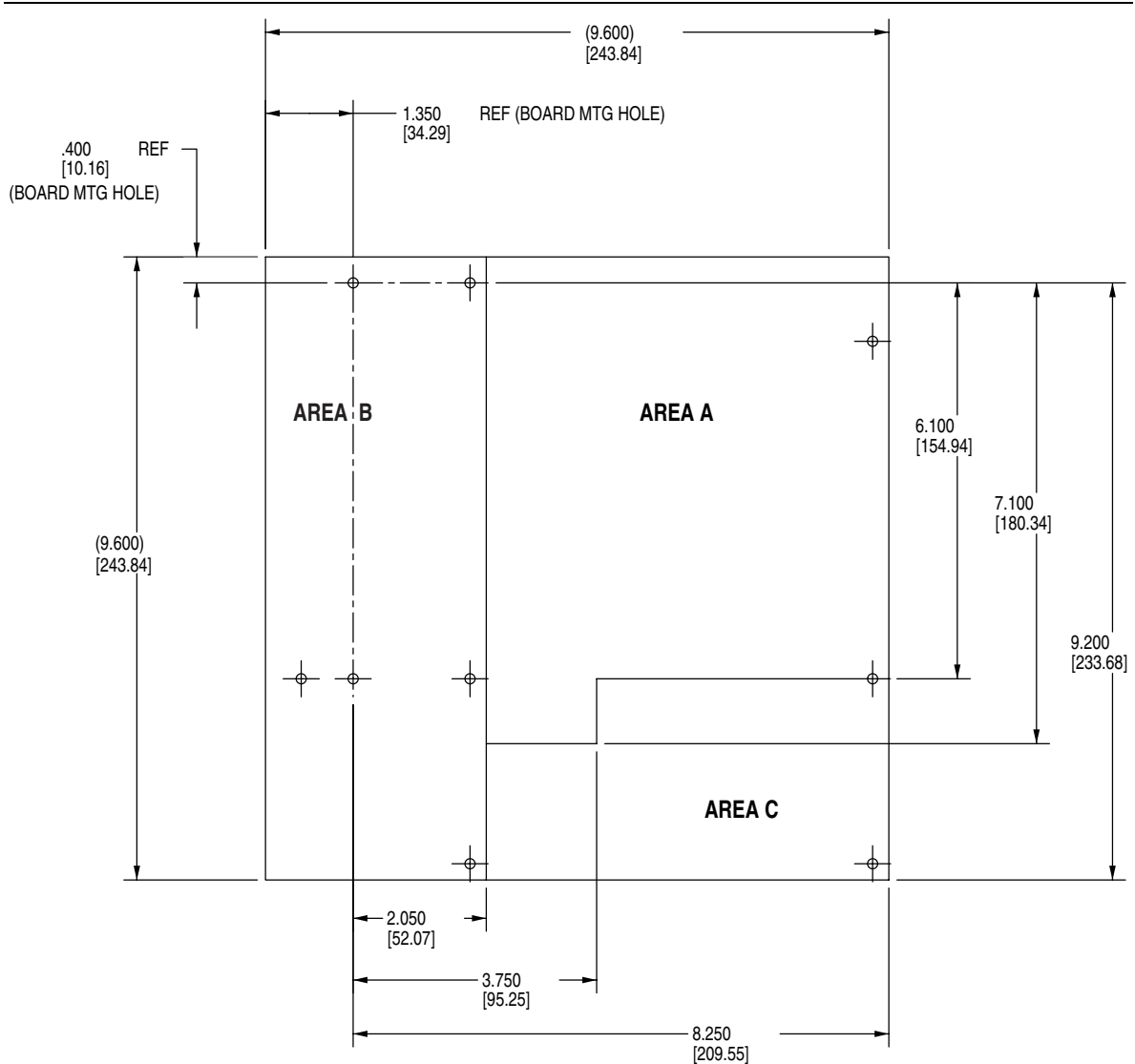

Area	Maximum component height (in inches)
A	Motherboard component height, 2.80 inches [71.12mm] maximum Chassis clearance over motherboard, 3.0 inches [76.20mm] required Chassis clearance over motherboard, 3.5 inches [88.90mm] recommended
B	0.60 inches [15.24mm] (expansion slot area)
C	1.50 inches [38.10mm] (see Notes)

Figure 7: microATX Motherboard Maximum Component Height Restrictions

Notes:

- Datum B 0,0 = mounting location hole B.
- The component height requirement assumes a motherboard thickness of 0.062" (1.57 mm). The maximum height specified for Area C is intended to avoid interference between motherboard components and the chassis structure and to provide backward-compatibility with microATX 1.0 or higher.
- When designing a microATX motherboard, attention should also be paid to keepouts specific to the specifications for the type of add-in card slots being integrated into the motherboard, which may have additional requirements for motherboard component heights. Examples of this are the PCI and AGP add-in card specifications which require a maximum component height in the area between the card connector and the rear panel that is less than the Area B component heights.

3. Power Supply Connector Information

3.1 20-pin Connector

The microATX and ATX specifications use a 20-pin main connector interface to the power supply (Figure 8). This interface incorporates standard $\pm 5V$, $\pm 12V$, 3.3V, 5V standby, and soft-power signals.

This board-mounted header can be implemented with a Molex 39-29-9202 or equivalent. This mates with the power supply connector, Molex 39-01-2200 or equivalent. All signals and power rails on the main power connector are required to be implemented for the main microATX power connector. This connector is identical to that defined for ATX 2.1.

Proper implementation of PS-ON, 5VSB, and PW-OK is **required** for an ATX-compliant power supply.

(Also main 3.3V sense)	3.3V	① ①	3.3V
	-12V	⑫ ⑫	3.3V
	COM	⑬ ⑬	COM
	PS-ON	⑭ ⑭	5V
	COM	⑮ ⑮	COM
	COM	⑯ ⑯	5V
	COM	⑰ ⑰	COM
	-5V*	⑱ ⑱	PW-OK
	5V	⑲ ⑲	5VSB
	5V	⑳ ⑲	12V

Figure 8: 20-pin Main Power Supply Connector Configuration (required for microATX)

Note:

- * All signals that can be carried on the 20-pin connector are not required or available on some power supplies. This optional signal (-5V) is not available in the TFX12V and SFX/SFX12V power supplies.

3.2 2x2 Connector

In addition to the 20-pin main connector, a 2x2 connector (shown in Figure 9) is utilized for +12 V power signals for the processor voltage regulator. For detailed information regarding the power supply or connectors for the microATX form factor, refer to the *SFX/SFX12V Power Supply Design Guide* or the *TFX12V Power Supply Design Guide*.

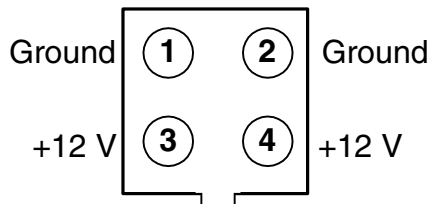

Figure 9: 2x2 Connector Configuration

3.3 Signal Control Definitions

3.3.1 PS-ON

PS-ON is an active low TTL signal that turns on all of the main power rails including 3.3V, 5V, -5V, 12V, and -12V power rails. When this signal is held high by the PC board or left open-circuited, outputs of the power rails should not deliver current. These outputs should be held at a zero potential with respect to ground. Power should be delivered to the rails only if the PS-ON signal is held at ground potential. This signal should be held at +5VDC by a pull-up resistor internal to the power supply.

3.3.2 5VSB

5VSB is a standby voltage that can be used to power circuits that require power input during the powered-down state of the power rails. The 5VSB pin should deliver $5V \pm 5\%$ at a minimum of 10mA for PC board circuits to operate. This power can be used to operate circuits such as soft-power control. It is highly recommended that the 5VSB line be capable of delivering a **minimum of 2.0A**. This current is needed for features such as Wake on LAN technology.^{††}

5VSB must be short-circuit protected to prevent damage to the power supply in the event a motherboard demands more 5VSB current than the power supply is rated for.

3.3.3 Power Good Signal, PW-OK

A “Power Good” signal, PW-OK, will be asserted (i.e., high) by the power supply to indicate that the outputs are above the undervoltage thresholds of the power supply and that sufficient mains energy is stored by the converter to guarantee continuous power operation within specification for at least the duration specified as “Hold Up Time.” Conversely, when one of these output voltages falls below the undervoltage threshold, or when mains power has been removed for a time sufficiently long to no longer guarantee power supply operation beyond the hold-up time, PW-OK will be held low. The **recommended** electrical and timing characteristics of the PW-OK signal are provided in the Power Supply Design Guidelines.

Motherboards should be designed so that the signal timings recommended in the Power Supply Design Guideline are used. If timings other than these are implemented or required, this information should be clearly specified.

3.4 Voltage Tolerances

Tolerance for the motherboard power rails should comply to the values listed in Table 7.

Table 7: Voltage Tolerances

Parameter	Range	Min.	Nom.	Max.	Unit
+12 VDC	± 5 %	+11.40	+12.00	+12.60	Volts
+ 5 VDC	± 5 %	+4.75	+5.00	+5.25	Volts
+3.3 VDC	± 5 %	+3.14	+3.30	+3.47	Volts
-12 VDC	± 10 %	-10.80	-12.00	-13.20	Volts
+ 5 VSB	± 5 %	+4.75	+5.00	+5.25	Volts

3.5 Optional 6-pin Power Connector

An optional 6-pin connector from the power supply can be used for such functions as fan monitoring, fan control, IEEE-1394 power source, and a remote 3.3V sense line. Although this connector is **not** required for ATX compliance, it can add benefits that are compelling for a full-featured system:

- The fan monitor features add the ability to monitor and detect fan failures.
- A built-in fan control allows the motherboard to request fan shutdown when the system goes into a sleep or suspend mode.
- Fan speed control is possible to allow for slower fan speeds during low power usage.

Figure 10 shows the pinout of the optional power connector. The PC board connector should be implemented with a Molex 39-30-1060 or equivalent connector. This mates with the power supply connector, Molex 39-01-2060 or equivalent. The exact location of this connector on the motherboard is not specified but should be near the main connector for convenience.

Proper implementation of FanM, FanC, 3.3V Sense, 1394V, and 1394R is discussed below. Except for FanM and 3.3Vsense (see note below figure), the signals should be implemented according to these specifications if an optional connector is used.

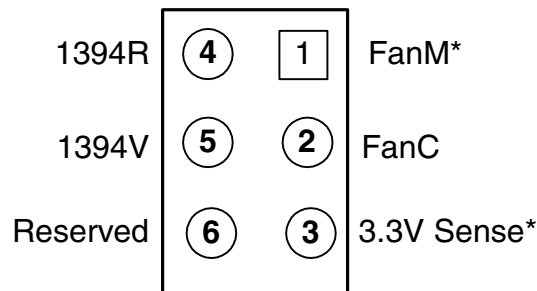

Figure 10: 6-pin Optional Power Supply Connector Configuration

(optional for microATX; used in ATX 2. 1)

Note:

- * All signals that can be carried on the 6-pin connector are not required or available on some power supplies. These optional signals are not available in the SFX/SFX12V or TFX12V power supplies: FanM and 3.3V Sense.

3.5.1 FanM Signal

The FanM signal is an open collector, 2 pulse per revolution tachometer signal from the power supply fan. The signal stops cycling during a lock rotor state; the level can be either high or low. This signal allows the system to monitor the power supply for fan speed or failures. Implementation of this signal would allow a system designer to gracefully power down the system in the case of a critical fan failure. The monitoring circuit on the motherboard should use a 1k Ohm to 10k Ohm pullup resistor for this signal. The output should be fed into a high impedance gate for the motherboard implementation. Figure 11 shows a simple illustration of the basic circuit requirements. If this signal is not implemented on the motherboard, it should not impact the power supply function.

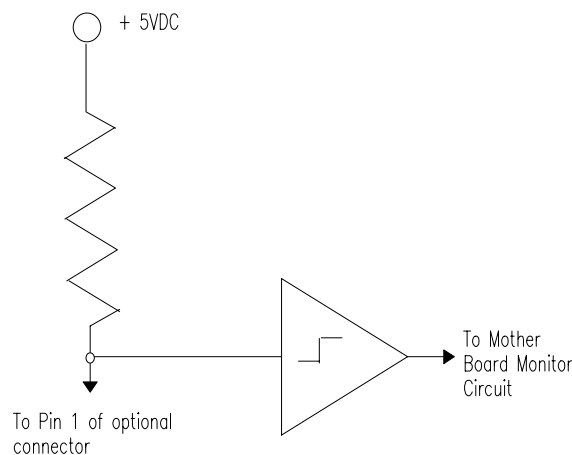

Figure 11: Simple Implementation of a Fan Monitor Circuit

3.5.2 FanC Signal

The FanC signal is an optional fan speed and shutdown control signal. The fan speed and shutdown are controlled by a variable voltage on this pin. This signal allows the system to request control of the power supply fan from full speed to off. Implementation of this signal would allow a system designer to implement a request-fan-speed control or shut-down during low power states such as sleep or suspend. The control circuit on the motherboard should supply voltage to this pin from +12 VDC to 0 VDC for the fan control request.

- If a voltage level of +1 volts or less is sensed by the power supply at pin 2 of the optional connector, the fan is requested by the motherboard to shut down.
- If a voltage level of +10.5 volts or higher is being supplied to pin 2, the fan in the power supply is requested to operate at full speed.

The fan control in the power supply can be implemented so that it allows variable speed operation of the fan, depending on the voltage level supplied. If, for example, a +6 volt signal is sensed at pin 2, the power supply would operate the fan at a medium speed. If this signal is used for on/off control of the power supply fan, and speed control is not implemented in the fan control circuit of the power supply, the power supply fan should operate at full speed for any voltage level over +1 VDC. The power supply should draw no more than 20mA from pin 2 of the optional power supply connector. A pullup resistor should be used internal to the power supply for this signal so that if the connector is left open, the fan will be requested to operate at full speed.

3.5.3 3.3V Sense Line

A remote 3.3 V sense line can be added to the optional connector to allow for accurate control of the 3.3VDC line directly at motherboard loads. Because of potential voltage drops across the connector and traces leading to the motherboard components, it can be advantageous to implement a 3.3V sense line that remotely monitors the 3.3VDC power level at the load on the motherboard. The implementation of this signal should be such that if an NC condition is detected on this line, the default 3.3V sense line on the main connector would be used for sensing the 3.3 VDC voltage level.

3.5.4 1394V Pin

This pin on the optional connector allows for implementation of a segregated voltage supply rail for use with unpowered IEEE-1394 solutions. The power derived from this pin should be used to power only 1394 connectors. The output of this power rail depends on the 1394 compatibility required. Use of this rail for motherboard or other power needs can have unpredictable results, because power for 1394 devices is not required to be regulated and can provide voltage levels between 8 and 40 volts. See the applicable IEEE-1394 specification for details on the specific power requirements for this rail. If this rail is implemented, it should operate such that the main PS-ON signal must be asserted low for power to be delivered at this connector.

3.5.5 1394R Pin

The 1394R pin provides an isolated ground path for unpowered 1394 implementations. This ground should be used only for 1394 connections and should be fully isolated from other ground planes in the system.